



# Customer Guide to Ai-Logix LD Integrations

# Customer Guide to Ai-Logix LD Integrations

- **Version** – This guide should be used with NICE Uptivity (formerly Uptivity Premise) v5.6 or later.
- **Copyright** – © 2020 inContact
- **Contact** – Send suggestions or corrections regarding this guide to [documentationrequests@incontact.com](mailto:documentationrequests@incontact.com).
- **Disclaimer** – inContact reserves the right to update or append this document, as needed.

# Table of Contents

---

- Integration Overview ..... 4
  - Cabling and Connections ..... 4
  - Premise Wiring Options ..... 4
  - Need-to-Knows ..... 6
  - Known Limitations and Considerations ..... 6
  - Customer Responsibilities ..... 7
  - Telephony Requirements ..... 7
  - NICE Uptivity Requirements ..... 7
  - Customer Configuration Overview ..... 8
- Customer Administration Tasks ..... 9
  - Channel Configuration Settings for Voice Boards ..... 9

# Integration Overview

This integration uses Ai-Logix LD cards to capture analog audio from either trunks or stations. Though most commonly used to capture telephone audio, LD cards can be used to record audio from any source that can be tapped (for example, radio base stations, PA systems, and so forth).

LD cards come in 4-port, 8-port, 16-port, and 24-port versions. Depending on the number of channels you want to record, multiple cards may be installed in a single NICE Uptivity system.

## Cabling and Connections

To ensure proper reception of audio to the LD boards, cabling lengths should be kept as short as possible. This applies between the tap point and the PBX, and between the tap point and the LD cards. Cables that are too long can cause degraded signaling, which in turn can result in poor quality or lost audio.

You should follow the AudioCodes recommendations for maximum cable lengths. This information can be obtained from AudioCodes Support website, or can be supplied by your NICE Uptivity Installation team upon request.

A 25-pair cable is routed between the demarcation point and the NICE Uptivity recording server. Connection type at the server end is a male RJ21X (amphenol) with a 180 degree connector (the Ai-Logix card connection is female).



**Note:**

A 180-degree connector is critical to allow the cable to be properly secured to the backplane of the server. The cards in this integration only use the first 24 pairs on the cable. The 25th pair is not used.

## Premise Wiring Options

Numerous methods can be used to wire stations into an Ai-Logix voice card, as illustrated in the following diagrams.

### TAP AT PBX INTO AI-LOGIX CARD

This method works best if most (nearly 100%) of the phones on the PBX are going to be tapped, or if all of the phones are arranged together on the same PBX station cards. This method employs an RJ21 Splitter, which is placed inline of an existing RJ21 feed to patch panels.

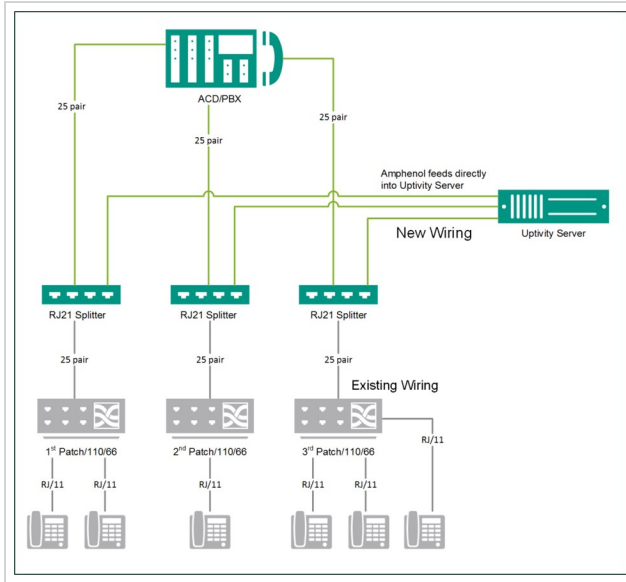

## TAP AT PBX INTO PATCH PANELS

If you need to make ongoing changes to your cabling, or you anticipate growth in the number of stations to be recorded, it may make sense to employ the previous method with one variation.

Instead of cabling directly from the RJ21 Y-Splitter, run the cables to terminate at an additional set of patch panels. These panels can then be used to step down feeds to the NICE Uptivity recording server.

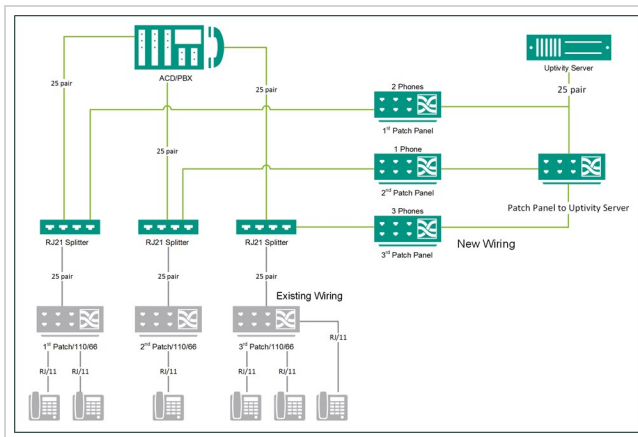

## TAP AT 110 OR 66 STATION BLOCKS

This method uses an existing patch panel as the tap point, which is often the simplest method. Existing wiring is replaced with an extended wiring pair, but is only “punched” at one point, not “cut” or “terminated.” This allows audio to be bridged from the PBX, to the phone, and then to the NICE Uptivity recording server.

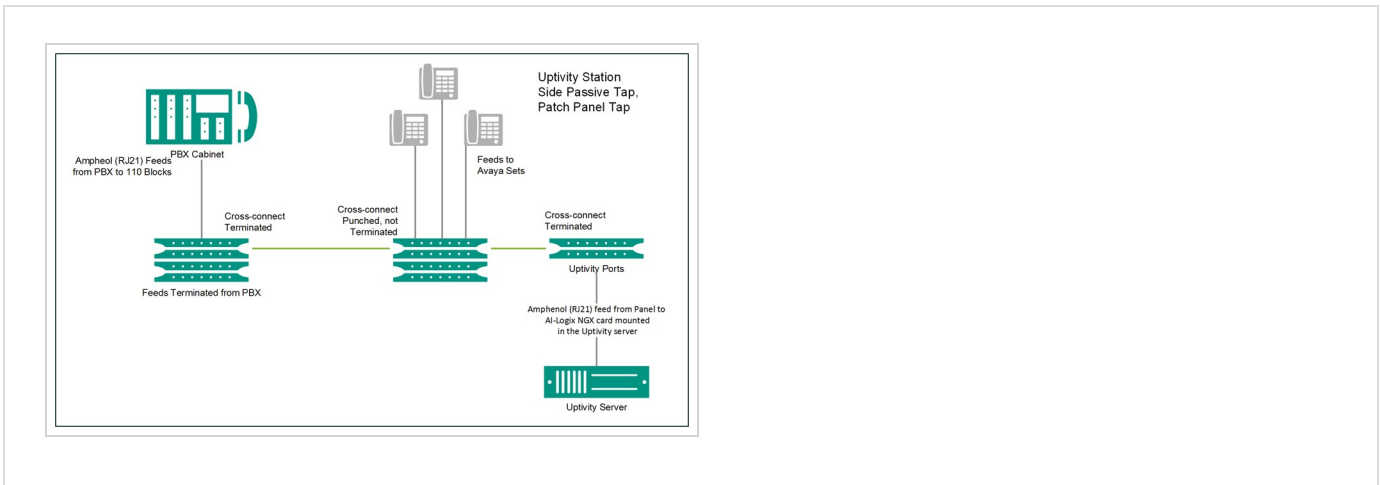

## “PUNCHLESS” WIRING INTEGRATION

It's possible to construct these scenarios in an arrangement where traditional punch tools are not required. Patch panels are available which accept an RJ21 connector bridged out to an RJ11 connector. Instead of using punched twisted-pair cable, you could then use standard RJ11 phone cords or RJ45 cables, provided that pin-outs are properly configured.

## SPLITJACKS AT PATCH PANEL

Some PBX models do not employ amphenol cabling (for example, certain Avaya models). Installing splitjacks at an RJ45 patch panel may be the easiest method in this scenario.

Using RJ45, you can purchase an RJ11 to RJ21 patch panel, which will accept an RJ45 connection. This method bridges the center pair into an amphenol connector wired into the patch. Cabling can then be run from an RJ45 splitter to the RJ11 panel, which in turn feeds an amphenol connection to the NICE Uptivity Server. If you split out an RJ45 connection, be certain that the splitter truly splits out all eight pairs across the connector.

## Need-to-Knows

Ai-Logix LD cards can be used to capture audio in combination with a separate CTI integration to your PBX for call control and metadata. In this scenario, refer to the applicable customer guide for your CTI integration for additional tasks and requirements.

## Known Limitations and Considerations

- Because this integration requires the use of physical audio capture cards, virtualization of the NICE Uptivity recording server is not supported.
- If the physical device is a 4-wire phone, two (2) channels on the Ai-Logix card are required to record the device.
- Ai-Logix integrations do not support the real-time blackout functionality in Uptivity.

- For environments that use Ai-Logix recording integrations with Uptivity, live monitoring is only supported when analog Ai-Logix cards are used with TDM phones or VoIP phones using the following codecs: G.711, G.729, iLBC, L16. Live monitoring is not supported with digital Ai-Logix cards.

## Customer Responsibilities

You are responsible for supplying the physical connections to your telephone system and data network, and for providing additional information about these connections to the NICE Uptivity installation team. If you supply the server hardware for the installation, then you are also responsible for installing the physical Ai-Logix cards in the server.

## Telephony Requirements

### HARDWARE

---

While recording is PBX-agnostic, some PBX hardware and phone models require special consideration. For details, refer to AudioCodes documentation or ask your NICE Uptivity Sales Engineer.

### SOFTWARE

---

There are no telephony software requirements for analog recording unless a PBX integration is used. Ask your NICE Uptivity Sales Engineer if you have questions.

### LICENSING

---

Additional licensing is usually not required, but certain manufacturers require licensing to allow station tapping. For details, refer to AudioCodes documentation or ask your NICE Uptivity Sales Engineer.

## NICE Uptivity Requirements

### HARDWARE

---

NICE Uptivity hardware requirements vary depending on system configurations. Appropriate hardware is identified during the system implementation process. Along with standard hardware, one or more of the following are specifically required for this integration based on the number of stations to be recorded:

- AudioCodes LDA409/809/1609/2409 Call Recording Blade

### SOFTWARE

---

This guide covers the following release:

- NICE Uptivity v5.6 or later

Additional third-party software is required for the Ai-Logix analog integration:

- AudioCodes SmartWORKS v3.11 - 5.4
- AudioCodes SmartWORKS v5.9 in MS 2012 environments

## LICENSING

---

- 1 Voice Seat license per physical device to be recorded if the device tap is a 2-wire phone OR
- 1 Voice Seat license per Ai-Logix card channel to be recorded if the device tap is a 4-wire phone OR
- 1 Voice Seat license per trunk channel to be recorded.
- Additional licensing may be required if the system includes optional features (for example, Uptivity Screen Recording).

## Customer Configuration Overview

1. Install the Ai-Logix cards in customer-supplied servers.
2. Complete all necessary physical connections between the recording servers and the telephony system.
3. Complete all necessary physical and IP connections between the recording servers and the LAN.



# Customer Administration Tasks

During ongoing use of the system, your Uptivity administrator may need to configure new channels or reconfigure existing channels. At those times, this integration requires changes to the Voice Boards page.

The number of voice board channels corresponds to the number of channels configured on the physical Ai-Logix card. Adding channels may require purchase and installation of server hardware and Uptivity licensing. Contact Uptivity Support for additional information.

For more information on voice board tasks, search online help for *voice boards*.

## Channel Configuration Settings for Voice Boards

This section provides a reference to channel settings that must be configured for the Ai-Logix LD integration. You should refer to this section whenever you add new channels to your Uptivity system.

Any other voice board changes should only be done under direct supervision from Uptivity Support. Done incorrectly, voice board modifications can have serious negative impact to your system. In addition, altering the hardware configuration of your system may void your warranty.

These settings apply when configuring channels for Ai-Logix LD integrations:

FIELD	DESCRIPTION	VALUE
<b>Assign</b>	Used in deployments where physical devices and channels have a one-to-one correspondence, or to allocate specific channels to specific types of recording. For details, search online help for <i>channel assignment</i> .	Dedicated Record (Device)
<b>Assign Value</b>	Enter the identifier for the device assigned to the channel (typically the phone extension). This value is case sensitive.	
<b>Name</b>	Enter an optional name for the channel that can be used in channel scripting.	
<b>Polarity</b>	Possible values: <i>Default, Normal, Reverse</i> . Should be set to match the polarity of the physical wiring taps. Typically, leave at <i>Default</i> .	
<b>Voltage Low</b>	Enter a value that can be used to determine when a physical phone has been taken off-hook. Required only when on/off hook signaling is used to determine recording start/stop.	
<b>Voltage High</b>	Enter a value that can be used to determine when a physical phone has been placed on-hook. Required only when on/off hook signaling is used to determine recording start/stop.	

FIELD	DESCRIPTION	VALUE
<b>Deglitch (ms)</b>	Determines the length of time in milliseconds that voltage must stay past the high or low threshold before an event is issued. Used only with voltage settings.	
<b>Trunk Tap</b>	Indicates whether to use the trunk-tap capability of the card.	