



CallCopy®

Innovations in Call Recording
and Contact Center Solutions

cc: Survey TDM Administration Guide, v5.2 R1

June 2013

Reference Guide

www.callcopy.com

Security Classification: CallCopy Confidential.

Distribution: Approved internal CallCopy staff only and licensed CallCopy customers.

Note: Applicable non-disclosure agreements must be in force for authorization.

Revision History			
Revision	Change Description	Author	Effective Date
0	Updated Product Technical Overview diagram. Noted that group permissions are not enforced in the Survey product.	MBuckingham	2013-05-31
1	Added requirement for UCIDs for Avaya TSAPI and related CM configuration and settings changes.	MBuckingham	2013-06-14

© Copyright 2014, CallCopy, Inc. All rights reserved.

No part of this document may be transmitted or distributed, or copied, photocopied, scanned, reproduced, translated, microfilmed, or otherwise duplicated on any medium without written consent of CallCopy. If written consent is given, the same confidential, proprietary, and copyright notices must be affixed to any permitted copies as were affixed to the original. The information contained in this document does not constitute legal advice, and should not be considered a replacement for sound legal counsel. CallCopy shall be in no way liable for any use or misuse of the information presented herein.

Table of Contents

Introduction	6
Product Technical Overview	7
Requirements	9
PBX	9
TDM/ISDN Supported PBXs	9
Hardware, Software, and Licensing	9
CallCopy	9
Hardware	9
Software	9
Licensing	9
Survey Call Linking	9
AudioCodes Configuration	10
Example Wiring	10
Board Configuration	11
Verify Board Service	12
PBX Configuration	13
Configure DNIS and ANI	13
Configure UCID	13
Install and Configure cc: Survey	15
Windows Server Tasks	15
Install the Server	15
Check INI Configuration	16
Register Service	17
Add the Application to the cc: Discover Service Manager	17
Add Survey Controller as an Allowed Application	18
Default Files	19
Security	19
Permissions	19
Encryption	19

Archiving	19
Configure Survey Score Linking to Calls	20
Install the Survey TSAPI Script	20
Update the Settings.ini File	20
Enable Survey Score Column in Call Lists	21
Survey Administration.....	22
Manage DNIS Values	22
Add/Edit/Delete Values	22
Import Multiple Values	22
Specify Survey Audio Directory Settings	23
Survey Forms	24
Specify Survey Information	24
Add a Section	24
Create a Question.....	25
Type: Present Question and Wait for Result.....	25
Type: Collect Customer Information	26
Type: Collect Digits.....	26
Type: End Survey	26
Type: Threshold Branch.....	26
Save/Export/Delete Survey Forms	27
Survey Forms Management	28
Reports	29
Reporting Criteria.....	29
Survey Detail	30
Survey Detail Summary	31
Survey Overview	31
Survey Summary	32
Survey Summary by Agent	33
Survey Summary by Question.....	34
Survey Summary by Response	35
Example PBX Configurations	37

AVAYA	37
DS1 Circuit Pack	37
Trunk Group Configuration.....	38
eOn eQueue.....	39
T1 Line Assignment.....	39
T1 Class.....	40
Port Class.....	40
ISDN Group.....	41
ISDN Parameter	41
Hotline.....	42
Nortel	43
About CallCopy	44

Introduction

This document explains the customer-premise based version of CallCopy's cc: Survey module. The document is for system administrators, survey administrators, and report users. It covers

- Equipment configuration for TDM
- Survey engine administration
- Survey form design and creation
- Reporting

Note For information on CallCopy's cc: Survey service, contact your CallCopy representative. That service provides all the functionality of the customer-premise based version, but CallCopy hosts and manages the equipment and data. Users are provided access to the surveys and reporting.

Product Technical Overview

This diagram illustrates the cc: Survey components and interactions.

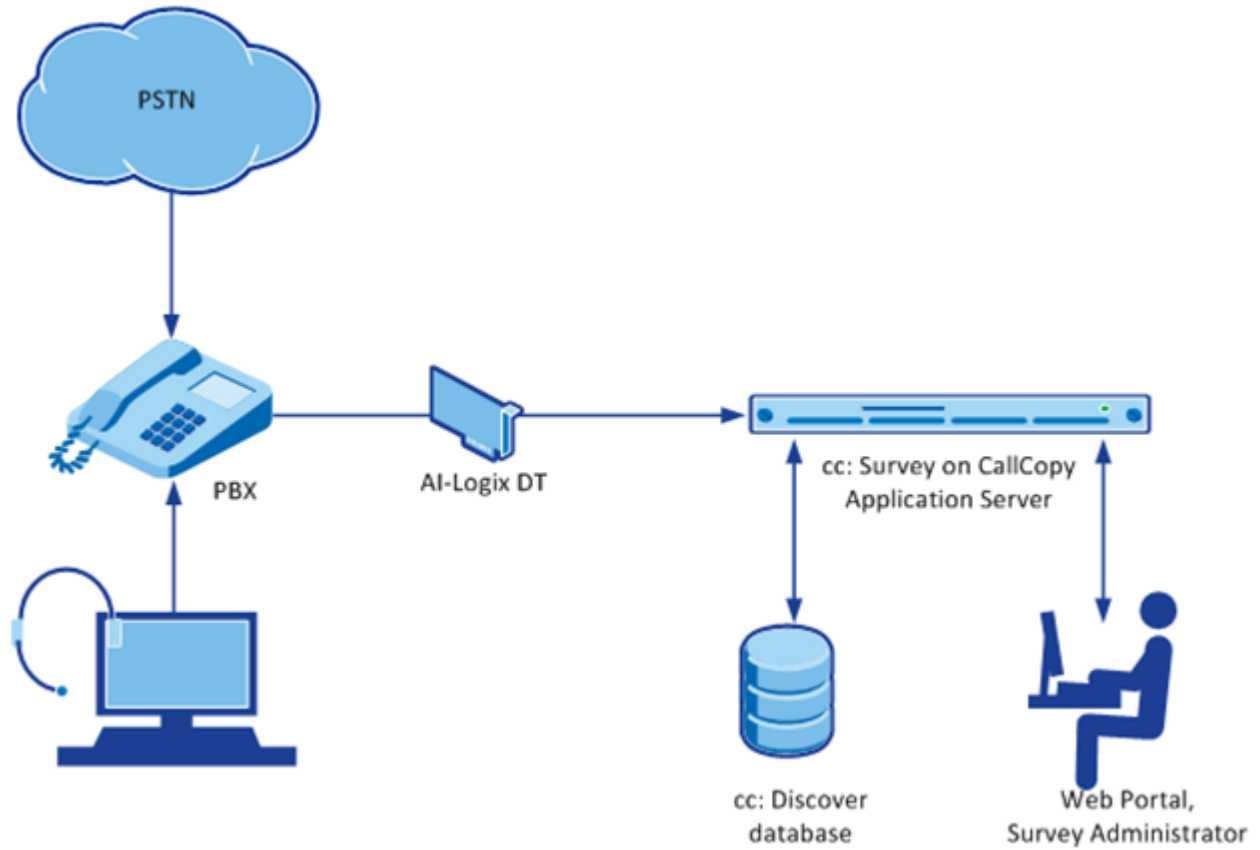

Component	Function
Callers via PSTN or Agents	<p>cc: Survey can be set up to handle calls two ways:</p> <ul style="list-style-type: none"> • A telephone number can be setup and provided to the public. Callers dial the number, and the PBX directs the call to the survey engine. • Agents can transfer callers to the survey engine via the PBX.
PBX	<p>A unique DNIS is created on the PBX for each survey. The PBX transfers calls from agents or toll-free numbers to the appropriate DNIS and survey.</p> <p>For each call, the PBX can send the survey engine the</p> <ul style="list-style-type: none"> • DNIS • Caller number or Agent/Extension number as an ANI
AI-Logix DT	<p>For a TDM network, cc: Survey connects to the PBX/ACD via a T1 trunk. This setup requires an AI-Logix DT voice board.</p>
cc: Survey	<p>cc: Survey consists of the survey engine that executes the survey forms and audio files, records respondent's input and call information to the database, and records respondents' voice comments to WAV files.</p> <p>The directories for the survey form, audio prompt, and verbal response files are located on this machine in most installations, although they can be located on a different machine.</p> <p>Survey and cc: Discover can be hosted by the same machine or separate machines. Survey can also be deployed without cc: Discover.</p>
cc: Discover Web Portal	<p>Administrators, system administrators, and managers use the Web Portal to</p> <ul style="list-style-type: none"> • Create and manage survey forms. • Configure and manage the server and users' permissions. • Review survey results, reports, and respondents' audio responses.
cc: Discover Database	<p>Call information and respondents' input and responses are recorded in this database as survey records. Reports are generated from these records.</p>

Requirements

PBX

TDM/ISDN Supported PBXs

All PBXs are supported but require an AI-Logix DT voice board.

Hardware, Software, and Licensing

Hardware and software requirements vary by PBX.

CallCopy

cc: Survey can be deployed with CallCopy's cc: Discover on the same machine, on a separate machine, or as a stand-alone product (i.e., no call recording). See the *cc: Discover Requirements* for additional requirements information.

Hardware

Hardware requirements vary depending on system configurations and usage requirements. Specifications are determined by the CallCopy Sales Engineering team during the sales process. For TDM/ISDN PBXs, the following items are specifically required:

- AudioCodes DT3209 (single span) T1 terminate board.

Software

This software is required:

- CallCopy cc: Discover Web Portal and database, v4.3 and higher
- AudioCodes SmartWORKS v5.2 or higher

Licensing

Contact your CallCopy representative for licensing information.

Survey Call Linking

This feature currently works only with TDM Survey installations in Avaya TSAPI environments.

AudioCodes Configuration

This chapter is only for users who will connect to the cc: Survey server via a TDM/ISDN PRI T-1 trunk. CallCopy uses AudioCodes AI-Logix DT-series boards to provide terminate connections to the customer PBX.

This chapter assumes that AudioCodes' SmartWORKS software has been installed.

Example Wiring

An example wiring diagram appears below. Note that the T1 might need to be connected via a cross-over cable if connecting to a PBX or ACD. For more information on wiring concerns, please reference the *AudioCodes SmartWORKS DT Quick Install* document.

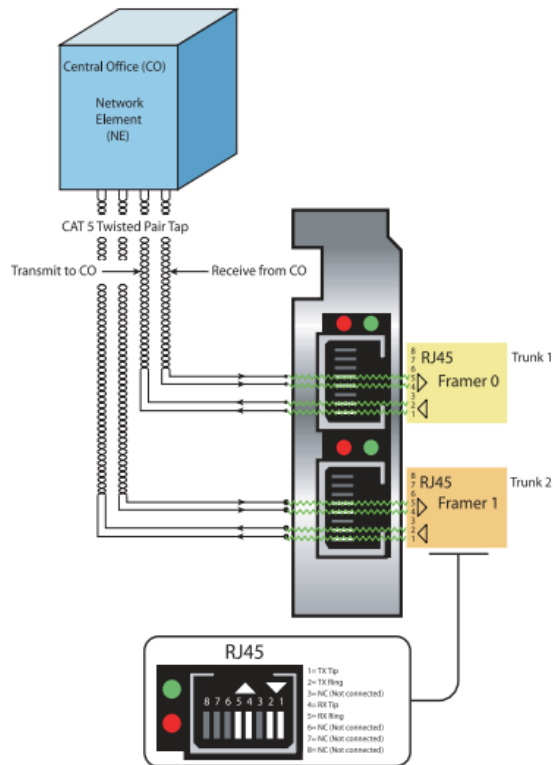

NOTE: A crossover cable is not required when installing a DT3209TE or a DT6409TE

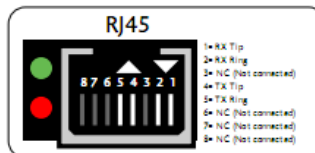

Board Configuration

The board settings have to match those on the customers' PBX. See section "[Example PBX Configurations.](#)"

A T1 deployed with a PRI layer is preferred for speed of connectivity.

To configure the SmartWORKS board, follow these steps:

1. Open the SmartControl Panel Applet located in the Control Panel.
2. On the **Board** tab of the window, verify the desired board number is selected. Confirm that the TDM Encoding setting is μ -Law.
3. Click the **Digital Network** tab. On this tab, the following Trunk Settings must be configured:
 - Framing: ESF
 - Line Coding: B8ZS
4. Configure these Protocol Settings:
 - Signaling Protocol: ISDN
 - Variant: National 2 (NI2)

This screenshot shows the configuration of a T1. The screenshot is for a board serving two T1s. Most cc: Survey systems will have only a single span available.

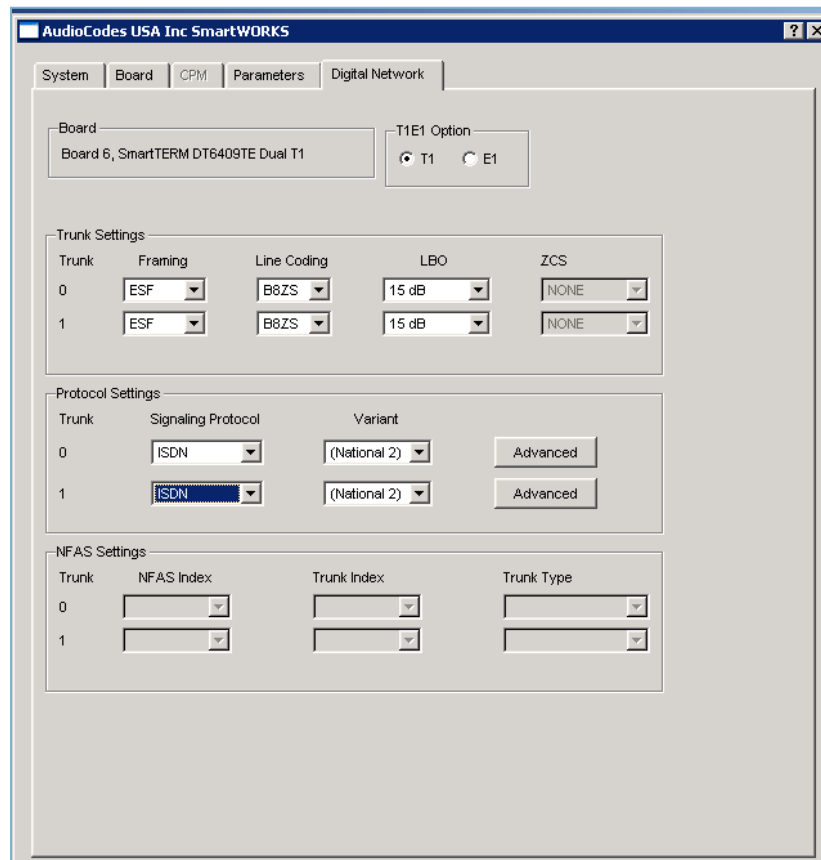

Verify Board Service

Proper operation of the board can be verified using the AudioCodes SmartView software that was installed with the SmartWORKS package. To open SmartView, from the Start menu select **Programs > AI-Logix > SmartWORKS > SmartView**.

From the menu bar, select **System > MTSysStartup**. This loads the driver, opens the board, and all channels.

At this point the system is set up to operate and capture events. To verify the board is in service, alarm states need to be checked. You can use these states to verify that the T1 layer is configured and connected cleanly to the CPE.

From the menu bar, select **FramerStatistics > MTGetT1/E1FramerStatistic**.

The following alarm screen is initiated:

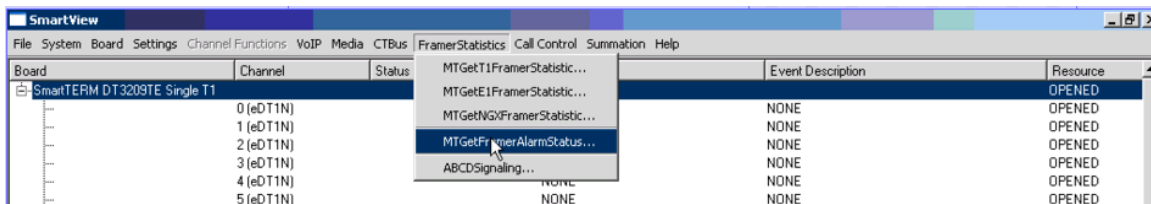

The following alarm screen is initiated. Any alarm value of greater than is indicative of wiring or configuration issue. Any alarm value of greater than 0 (or --) is indicative of wiring or configuration issue. Reference the *AudioCodes SmartWORKS DT Quick Install* document for troubleshooting.

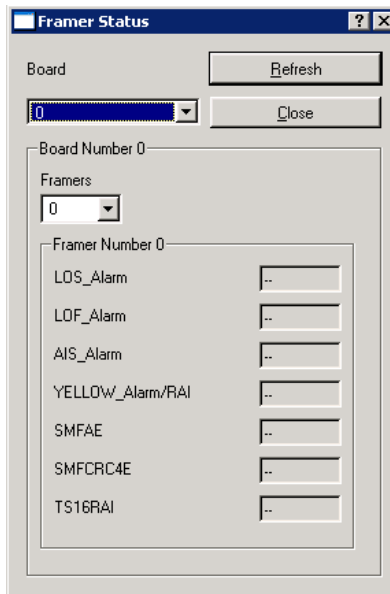

PBX Configuration

See your PBX documentation for specific steps to perform the tasks mentioned in this section.

Configure DNIS and ANI

The following PBX configurations must be set:

- A unique DNIS for each survey.
- Call routing to direct both direct calls (i.e., 1-800 calls from customers) and forwarded calls to the cc: Survey engine.
- A dial plan to pass the DNIS and the ANI (i.e., the originating caller or the transferring agent's PBX number -- either the Agent or the Extension) to the Survey engine.

Configure UCID

In order for Avaya TSAPI survey linking to work properly, the Avaya CM must be configured to send UCID to the CallCopy core so that it is captured on every call. This can be set up from the CM console.

1. Log into the CM.
2. Run the following command: **change system-parameters features**
3. Browse to and set the following settings to **Y**:
 - Create Universal Call ID (UCID)?

```

change system-parameters features                                     Page 5 of 19
                                FEATURE-RELATED SYSTEM PARAMETERS

SYSTEM PRINTER PARAMETERS
  Endpoint: _____ Lines Per Page: 60

SYSTEM-WIDE PARAMETERS
                                Switch Name: CallCopy
  Emergency Extension Forwarding (min): 10
  Enable Inter-Gateway Alternate Routing? y IGAR Over IP Trunks: skip
  Enable Dial Plan Transparency in Survivable Mode? n
                                COR to Use for DPT: station

MALICIOUS CALL TRACE PARAMETERS
  Apply MCT Warning Tone? n MCT Voice Recorder Trunk Group: _____
  Delay Sending RElease (seconds): 0

SEND ALL CALLS OPTIONS
  Send All Calls Applies to: station Auto Inspect on Send All Calls? n
  Preserve previous AUX Work button states after deactivation? n

UNIVERSAL CALL ID
  Create Universal Call ID (UCID)? y UCID Network Node ID: 4

```

- Send UCID to ASAI?

```
change system-parameters features Page 13 of 19
FEATURE-RELATED SYSTEM PARAMETERS
CALL CENTER MISCELLANEOUS
  Callr-info Display Timer (sec): 10
  Clear Callr-info: next-call
  Allow Ringer-off with Auto-Answer? n
  Reporting for PC Non-Predictive Calls? n
  Agent/Caller Disconnect Tones? n
  Interruptible Aux Notification Timer (sec): 3
  Zip Tone Burst for Callmaster Endpoints: double
ASAI
  Copy ASAI UUI During Conference/Transfer? n
  Call Classification After Answer Supervision? u
  Send UCID to ASAI? u
  For ASAI Send DTMF Tone to Call Originator? u
```

4. Save the changes.

Install and Configure cc: Survey

This section explains the tasks for installing cc: Survey. Survey can be deployed

- On the same machine as cc: Discover – Only the instructions in this section are needed.
- On a separate machine from cc: Discover –
 - Complete the instructions in this section.
 - Install the cc: Discover Logger service (Logger.exe) and CometDaemon.
 - On the cc: Discover Web Portal machine, create a new server node and Comet Daemon entry for the Survey machine.
 - Add the Survey machine and both the Logger and Survey to the Service Manager in the Web Portal.
- Without call recording – Complete the cc: Discover installation, skipping tasks for call recording.

Check the *cc: Discover Installation Guide* and *cc: Discover Administration Manual* for instructions on the above tasks.

Windows Server Tasks

Perform these tasks on the Windows server hosting cc: Survey.

Install the Server

The cc: Survey server is included with the base cc: Discover install package. Run the installer and select Survey as a feature to be installed. For more information, see the *cc: Discover Installation Guide*.

Check INI Configuration

cc: Survey initialization settings are stored in the settings.ini file used by the cc: Discover database. These settings **must** be configured for the proper operation of the server. The file is located in the base folder where the cc: Discover software was installed.

These are the configuration settings:

[surveys]	Description
NumberOfAudiocodesChannels=	Number of voice board channels. Required for TDM.
MaximumDigitLengthForAPrompt=	Maximum number of digits the survey will expect to collect. Optional for Both, used when you want to be able to have answers that are more than digit.
PutANIInDigitString=	This is used if the PBX is not passing ANI/Survey ID in the digit string. Possible values: Y or N. Optional for Both, used when the PBX isn't sending an ANI*DNIS string, it is only sending a DNIS string.
SurveyEngineType=	All non-legacy survey servers should be CCSURVEYENGINE. Possible values: CCSURVEYENGINE or SOAP. Optional for current versions, it defaults to CCSURVEYENGINE if not set.
RepeatQuestionAfterInvalid=	Used if there is an Invalid_Response file setup and the question must be repeated. Possible values: Y or N. Optional for Both, used when you want to repeat the question when an invalid digit is pressed.
DigitTimeOut=	Length of time Survey waits if the respondent has to enter digits. Possible values: an integer representing milliseconds (i.e., 3000 is 3 seconds). Optional for Both, used when you want to increase the time the survey waits to collect digits on the collect digit survey type.
SoapURL=	Only used by the legacy SOAP engine. Deprecated, only required for legacy.
SoapWSDL=	Only used by the legacy SOAP engine. Deprecated, only required for legacy.

Register Service

To ensure normal survey operations, the survey engine should be registered as a service on the Windows server:

Open a Command Prompt window on the Windows server. Change to the CallCopy Recorder directory. From the directory, run the following command:

```
cc_SurveyControllerIVR.exe -install
```

If successful, the Command Prompt will display the message “Service Installed.”

Add the Application to the cc: Discover Service Manager

To add the service to the Service Manager, follow the listed steps.

1. Click the cc: Discover Administration tab > Tools > Service Manager.
2. Locate and expand the node created earlier.
3. Click **Add Application**.
4. In the new line, enter the following information:
 - **Application Name:** Enter **CallCopySurveyControllerService**
 - **Auto-Restart:** Select Yes to have the service restarted automatically if it is stopped.
5. Click **Save**.

Add Survey Controller as an Allowed Application

Windows' Data Execution Prevention (DEP) setting helps protect against viruses and other security threats. The Survey Controller (cc_SurveyControllerIVR.exe) must be added to the DEP setting in order to perform remote data execution.

If this setting is NOT set, the IVR will respond with an "Access Violation" message on the respondent's phone, and the violation will also be logged in the CCSurvey-*.log files where * is the channel number.

Perform these steps on the Windows server:

1. Go to Control Panel > System > Advanced > Performance – Settings > Data Execution Prevention.
2. Click **Add**.
3. Navigate to the folder where the survey software was installed and select cc_SurveyControllerIVR.exe. Click **OK**. (If you are prompted to insert a disk, click **Cancel** and continue with this step.)

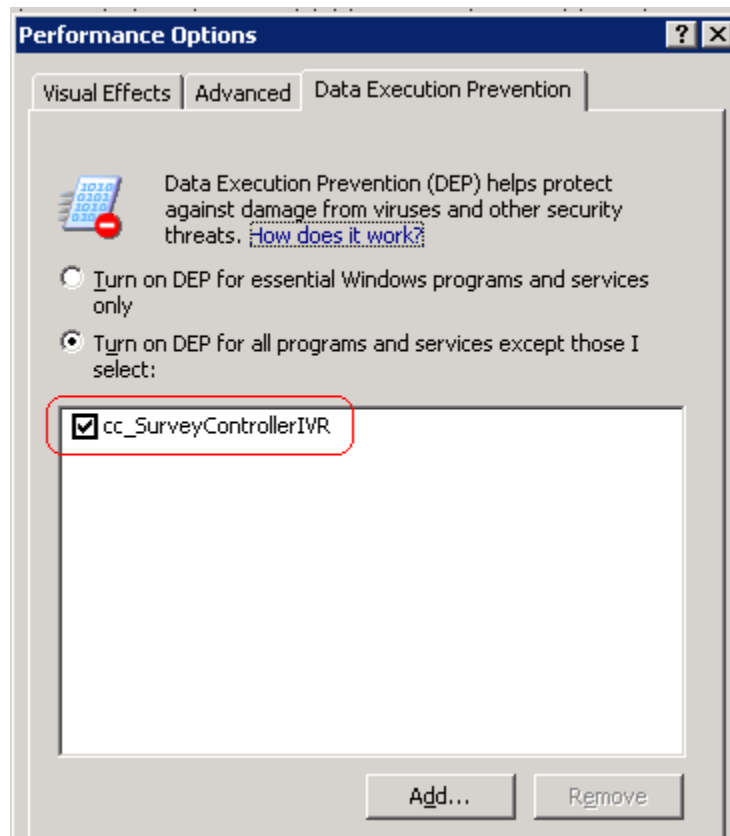

Default Files

If you're doing a **TDM** installation, manually create the Prompts folder in the Recorder directory and copy into it the files stored here: \\storage02\callcopy_releases\Survey\TDMPrompts.

Security

Permissions

Users must be granted the permissions to view, edit, and administer surveys. See the *cc: Discover Administration Manual* for further information.

Note Group permissions are not enforced by the survey product. A user who has access to survey reports can see survey results for any agent.

These components need these permissions setup:

- IIS account running cc: Discover Web Portal – Read/Write permissions to the Audio Prompt Upload Directory and the Audio Recording Directory. If Survey is installed on a **separate machine** from Web Portal, the IIS account must be a service account with explicit read/write access to the prompts and recordings directories on the Survey server.
- Survey Module – Read permission to the Audio Prompt Upload Directory. Write permission to the Audio Recording Directory.
- Reporting server – Read permission to the Audio Recording Directory if respondents are allowed to leave audio responses to questions.

The install program set permissions needed for the database and other CallCopy modules.

Encryption

The audio prompt and audio response recordings are not encrypted. Typically, surveys should not provide respondents sensitive information or ask them to provide sensitive information.

Archiving

cc: Survey's audio files are not archived.

Configure Survey Score Linking to Calls

This feature currently works only with TDM Survey installations in Avaya TSAPI environments that have been configured to send UCID to the CallCopy core for every call.

Install the Survey TSAPI Script

1. Browse to the directory containing **cc_SurveyControllerIVR.exe**, typically **C:\Program Files (x86)\CallCopy\Recordings**.
2. Create a **Scripts** folder in that directory.
3. Check with Development to determine which script file needs to be copied to the Scripts folder.

Update the Settings.ini File

1. Locate a transfer to Survey in the Avaya TSAPI channel events log. You should see the trunk identifier (trunkGroup_#=) in the message. Refer to the example below.

```
2012-06-05 07:35:05.990      Info    0      Channel 0[1155] Type:
CTI_EVENT_AVAYA_TSAPI 8216(67) CSTA_TRANSFERRED IP:
2012-06-05 07:35:05.990      Info    0      Channel 0[1155]
Msg=>timeReceived=07:35:05.943|eventType=67|eventClass=4|monitorCrossRefId=8|primaryOldCallID
=14730|secondaryOldCallID=14705|transferringDevice=8305|transferredDevice=8305|primaryOldDeviceI
D=8305|secondaryOldDeviceID=8305|numberOfTrunks=1|trunkInfoCallId_0=14705|trunkInfoDeviceId_0=
T14705#1|trunkGroup_0=5|trunkMember_0=17|oci_ucid=00000000000000000000|oci_trunkGroup=|oci
_trunkMember=|oci_calledDevice=|oci_callingDevice=|ucid=00001147051338899665|attEventType=132<
==
```

2. Add the following entries to the settings.ini file (in C:\Program Files (x86)\CallCopy). The "AvayaTsapi" settings must be the same as those set on the Core's Avaya TSAPI CTI module.

[settings]	Tells the survey module to load the TSAPI module.
modules=	Value should be AvayaTsapi .
[AvayaTsapi]	Tells the survey module how to configure the TSAPI module; settings should match the TSAPI settings from the core that is recording the calls being transferred.
Servername=	Refer to customer's TSAPI CTI module settings.
serverusername=	Refer to customer's TSAPI CTI module settings.
serverpassword=	Refer to customer's TSAPI CTI module settings.
tsversion=	Refer to customer's TSAPI CTI module settings.

privatedatatype=	Refer to customer's TSAPI CTI module settings.
vdns=	VDN(s) used to transfer calls to the IVR; if more than one, separate them with a comma.
groups=	Add any hunt groups in order to get agent logins; if more than one, separate them with a comma
[scripting]	Tells the survey engine which column to match for recordings. UCID is in user8 for TSAPI by default.
recordingmatchcolumn=	Set to match the column being used to store UCID, which is required to link surveys. The default column is user8.
[Surveys]	Settings for the IVR, the channel settings alter what number the board is treated as. This way we can match TSAPI info to the board and channel from IVR.
NumberOfAudiocodesChannels=	Customer should provide the number of audio channels they are using.
PutANIInDigitString=	Should be set to Y.
Channel0BoardTrunk= Channel1BoardTrunk=	Defined in the first step in this section. Enter the corresponding value for each channel. If the customer has another trunk, they will need to find that identifier for that trunk and repeat this sequence for the channels that relate to that trunk.

Enable Survey Score Column in Call Lists

This task can be performed by an administrator or each user.

1. Log into cc: Discover.
2. Go to Web Player tab > Call Lists.
3. Click **Settings** in the upper-right corner.
4. Under **Other Columns**, select the box for **Survey Score**.
5. Click **Save**.

Survey Administration

Manage DNIS Values

A DNIS is a unique identifier that the phone system (PBX) sends to the survey application. The DNIS allows specific surveys to be associated with specific dialed numbers (DNIS). Using this methodology one survey engine can support an infinite number of unique surveys, each playing their own messages and asking for their own responses.

Add/Edit/Delete Values

Follow these steps to add DNIS values:

1. Log into the cc: Discover Web Portal and click Administration > Add-Ons > Surveys > DNIS List.
2. Click **Add**.
3. Enter a DNIS value and Comment value. The comment can be a client name or some explanation of how the DNIS will be used in the survey work.
4. Click the floppy disk icon to save the record.

Values can be edited or deleted by clicking the pencil and red X icons.

Import Multiple Values

Multiple DNIS values can be added at one time using a CSV file. For example, all the DNIS values used by your phones can be entered. This action avoids the repetitive work of entering values each time one or more is needed for a survey. Surveys are not applied to calls received through a DNIS until that DNIS is assigned to a survey form.

Entries in the CSV file must fit this format: DNIS, Comment. Each entry should be on a separate line. A CSV can also be created in an Excel spreadsheet. Some equipment export DNIS data as a file.

After creating the CSV file, follow these steps to import the DNIS values:

1. Log into the cc: Discover Web Portal and click Administration > Add-Ons > Surveys > DNIS List.
2. Click **Import**.
3. Browse to the location of the CSV file. Select it and click **OK**.
4. If the first row in the CSV file is NOT a header (i.e., it is a DNIS/Comment value), clear the File contains a header row option.
5. Click **Upload File**. Review the records that are ready for importing. If any of the records are not correct, click **Cancel**. Edit the file and repeat the import. Otherwise, go to the next step.
6. If the records are correct, click **Import**. The DNIS values appear as records in the list.

Specify Survey Audio Directory Settings

cc: Survey requires these two directories:

- Audio Prompt Upload Directory – This is where messages and prompts are stored on the server's hard drive.
- Audio Recording Directory – This is the location on the server's hard drive array where customer feedback recordings are stored.

Follow these steps to specify the directories:

1. Create the directories in the file system. cc: Discover does not require that they be specific names. Example: c:\SurveyPrompts.
2. Log into the cc: Discover Web Portal and click Administration > Add-Ons > Surveys > Survey Settings.
3. Enter full path names for both directories.
4. Click **Save**. The settings will be saved if the directory paths are correct, the directories exist, and the application has Create/Write permission for both directories.

Survey Forms

The Survey Editor enables you to create new surveys and edit existing ones.

To create a survey form, you must perform the tasks explained in this section.

Tip CallCopy recommends creating survey questions, responses, and actions on paper before trying to create the form.

Specify Survey Information

1. Log into the cc: Discover Web Portal and click Surveys > Create Survey.
2. Enter a Survey Name. This name appears in reports. For ease of use, form names should be unique and describe the survey.
3. Enter a Description.
4. Enter Min/Max Percentage Thresholds. Any survey whose score is below the minimum percentage is defined as “Negative.” Any survey whose score is above the maximum percentage is defined as “Positive.” Any score between the minimum and maximum thresholds is reported as “Neutral.” These values appear on the Survey Summary and Survey Overview Reports.
5. Select a Recording Format. This is the format of customer feedback messages that are recorded by the customer when completing a survey. The only supported format is GSM, which is a highly compressed WAV format.

Note The Recording Path (Audio Recording Directory) and Upload Path (Audio Prompt Upload Directory) are specified on the Administration > Add-Ons > Survey Settings page. cc: Survey automatically creates a new folder for each survey. The folder is numbered according to the number of survey forms created (i.e., the tenth survey is placed in a folder number '10').

6. In the Available DNIS field, select the number whose calls will be directed to this survey. Click the top arrow to move the number to the Attached DNIS field.

Add a Section

The survey form is divided into sections consisting of one or more questions. A survey has to have at least one section, and all questions can be placed in that section. Sections can be an easy way to organize longer surveys. Sections do not affect how respondents experience the survey or the reporting of survey answers.

Follow these steps to add a section:

1. Click **Add New Section**.
2. Enter a section title.

Use the  buttons to move sections and questions up or down or to delete them.

Create a Question

Follow these steps to create a question:

1. Click **Add New Question**.
2. In the Question #X Text box, enter the text of the question. This text is displayed as a label in the reporting engine. This text should correspond to the language within the recorded audio file associated with the question for consistency and future troubleshooting.
3. Select a Question Type. See the specific question types below for additional information.
4. Click **Upload Audio File** and navigate to the file with the question. This is the location of the recording audio file stored on the survey application survey's hard drive structure. These files can be copied to the server locations manually if you have access to the server's drive array.
5. (Optional) Select the Mark Survey Complete option. This value marks a survey as being complete. You can require certain questions to be responded to in order for the data to be presented within reporting. For example, if you have a 5 question survey, and completing Question 4 marks the survey as "complete," the customer could hang up and not complete Question 5, yet the survey would still display the data within reporting. Question 5 would be scored as 0 out of the possible points for Question 5, in this example. Any survey not reaching Question 4 would be marked as "incomplete."
6. (Optional) Clear the Show-in-Reporting option. Use this option if you do not want this question included within the reporting values, such as greetings, closings, or transitions without responses. Otherwise, this question will display with no data responses.

Notes

- Response Type is currently not used by audio-based surveys. This is reserved for future use within web browser-based surveys.
- Possible Points is auto-calculated based on the highest response defined on the list of responses to questions of the type "Present Question and Wait for Result".

Type: Present Question and Wait for Result

This type can present

- A question and wait for touch-tone input. In this use, the audio file must state each possible response and corresponding touch-tone input value. Questions of this type usually need at least two responses.
- Information, such as instructions or a greeting, and advance automatically after a wait period configured in the server.

The following values are available for defining specific responses:

- Text -- Label of the response as it appears on reports.
- Point Value -- Value of the specific response selected. (Optional)
- DTMF -- This is the touch-tone input value for the response. Each DTMF field for a question must have a unique value.
- Next Question -- After you have created other questions, you can return to set this option. You can select the next question presented in the survey based on the particular response.

Type: Collect Customer Information

This type allows the customer to leave detailed feedback in the form of a voice recording. There is no preset or configurable limit for the length of these recordings, and are only bound by available disk space.

If you wish the customer to continue on with other survey questions after leaving verbal feedback, specify within the question audio file to press the “Pound or hash” sign to end the recording (#). This tone instructs the survey engine to continue processing the survey.

The survey recorder will continue recording until the respondent either hangs up or pushes the pound sign (#).

You have to set a Default Next Question. To do so, you have to create additional questions and then return to setting this option.

The voice recordings can be listened to from reports. The files can be accessed from the Audio Recording Directory.

Type: Collect Digits

This type is used to collect a specific digit string to be stored within the database. This is useful for collecting a customer ID or transaction number. The survey recorder advances when the respondent pushes the pound sign (#) or the wait period is reached.

Type: End Survey

Include this question/item at the end of a survey. After the audio file has executed, the survey session is ended, and the call is automatically disconnected.

Type: Threshold Branch

A Threshold Branch is not a question. It enables you to direct respondents to specific questions based on the cumulative score of earlier responses. Respondents do not know that they are being directed based on their responses, and no audio file has to be loaded for this type. Typically, you don't include a Mark Survey Complete option here unless you want to end the survey.

For this question type, these fields are available:

- Question Text – Enter a description of the branch criteria.
- Negative Percentage Threshold – Surveys with a current percentage (current accumulated points/current total possible points) below this value are considered negative.
- Positive Percentage Threshold – Surveys with a current percentage above this value are considered positive.
- Negative Next Question – Next question for surveys that are currently negative.
- Neutral Next Question – Next question for surveys that are between the Negative and Positive Thresholds.
- Positive Next Question – Next question for surveys that are currently positive.

Save/Export/Delete Survey Forms

The Survey Form Editor allows you to

- Save – This option saves and closes the form. After it is saved, the form appears in the Form Manager list.
- Save Draft – The form is saved and appears in the Form Manager list as 'In Progress'.
- Delete – Do not delete forms. If they are not needed, disable them on the Form Manager page.
- Export – This option exports the form as an XML file. It can be imported on the Form Manager page.

cc: Survey auto-saves the form while you work with it. The Save Draft and Save options identify any missing required field data.

Survey Forms Management

To see all existing forms in the Web Portal, click Surveys > Manage Surveys.

Select one of the options from the Filter By Status menu:

- All
- Active – Surveys that are currently used.
- Disabled – Surveys that are not currently used but can be made active.
- In Progress – Surveys that have been saved as drafts and require additional editing before they can be used.

From the Survey Form Listing, you can

- Click **Edit** to open the survey form in the editor.
- Change a form’s status by selecting or clearing its Active/Disabled option.

Survey Forms Listing								
<input type="button" value="Import"/> Filter By Status: All								
	Name	Status	DNIS	Attempted Count	Created By	Created On	Last Modified By	Last Modified On
<input type="button" value="Edit"/>	Agent Satisfaction Survey	<input type="checkbox"/> Disabled		0	Administrator	9/20/2011 2:38:17 PM	Administrator	9/20/2011 3:50:00 PM
<input type="button" value="Edit"/>	CallCopy 1	In Progress		0	Administrator	9/20/2011 3:59:52 PM	Administrator	9/20/2011 4:00:25 PM
<input type="button" value="Edit"/>	Charity Service	<input checked="" type="checkbox"/> Active	4177	0	Administrator	9/20/2011 10:18:59 AM	Administrator	9/20/2011 3:50:48 PM
<input type="button" value="Edit"/>	Customer ABC	<input checked="" type="checkbox"/> Active	4520	0	Administrator	9/16/2011 4:37:27 PM	Administrator	9/20/2011 3:57:43 PM
<input type="button" value="Edit"/>	Customer XZY	<input checked="" type="checkbox"/> Active	4521	0	Administrator	9/20/2011 1:37:46 PM	Administrator	9/20/2011 3:52:28 PM

Pages : Go To Page : of 1

The Attempted Count value indicates the number of respondents who have started the survey form.

The Import button can be used to load XML files and use them as Survey Forms. The files must be formatted exactly as those created using the Form Editor. Custom forms are not supported.

Reports

(See the *cc: Discover Reporting Manual* for additional information about the Reporting tab's functions.)

Survey reports can be accessed through the cc: Discover Web Portal. On the Reporting tab, click Printable Reports > Survey Reporting.

The Survey Reporting page lists the types of reports that can be created. The Date Created column shows the date that the template for the report type was created in the system.

Reporting Criteria

You can use these criteria to specify the data included in a report. The criteria available vary by report.

- Start/End Date – Searched calls will have occurred during this date range.
- Agent – One or all agents can be selected.
- Record ID – This is the survey database record ID.
- Surveys/Form ID – One, multiple, or all survey forms can be selected.
- Survey Complete – Surveys are either Complete or Incomplete based on whether the respondent reached a question that had the Mark Survey Complete option selected.
- ANI – This is the respondent's telephone number.

Note If the respondent was manually redirected to the survey by an agent, this number may not be accurate, depending on telephony equipment.

- DNIS – This is the number associated with the survey.

Survey Detail

This report shows one or more survey taker's complete responses.



Survey Detail

For period beginning 1/27/2011 and ending 9/27/2011

Form:	CallCopy Customer Survey	Record:	53190
DNIS:	7533 ANI: 5010 Survey	Date:	4/1/2011 9:38 AM
Survey Complete:	Yes	IP Address:	
Satisfaction		Score: 10 of 10 (100%)	
On a scale of one to five, five being the highest, how satisfied are you with the CallCopy software solution overall?			
Digits Collected: 5			
5		<input checked="" type="checkbox"/>	5pts
4		<input type="checkbox"/>	
3		<input type="checkbox"/>	
2		<input type="checkbox"/>	
1		<input type="checkbox"/>	

If respondents left a voice message for a question, a link to the message file appears in the report.

Note IP Address is not used at this time.

Close	Score: 0 of 0 (N/A)
Finally, one last question. If you could have one product enhancement, what would it be?	
	<input type="checkbox"/>
2-101411.wav	

Survey Detail Summary

This report lists all survey responses that match the search criteria. Click a survey to open the Survey Detail report for that survey. The Recordings column shows the number, if any, of respondent voice recordings.



Survey Detail Summary

For period beginning Tuesday, May 08, 2012 and ending Friday, June 08, 2012

Selected Surveys: surveyFor5090

Survey Complete: Complete

Name	Date	DNIS	ANI	Score	RecordID	Recordings	Agent Name
surveyFor5090	5/9/2012	1001	1234	46.67%	5	0	agent9_first58 agent9_last58
surveyFor5090	5/9/2012	1001	1234	46.67%	6	0	Clifton Guiran
surveyFor5090	5/9/2012	1001	1234	60.00%	7	0	agent10_first58 agent10_last58
surveyFor5090	5/9/2012	1001	1234	53.33%	8	0	Alan Crow
surveyFor5090	5/9/2012	1001	1234	80.00%	9	0	Myron Galliano
surveyFor5090	5/9/2012	1001	1234	0.00%	10	0	Connie Francis
surveyFor5090	5/9/2012	1001	1234	40.00%	11	0	Connie Francis
surveyFor5090	5/9/2012	1001	1234	60.00%	12	0	agent10_first58 agent10_last58

Survey Overview

For each survey form in a time period, the report calculates the shown categories. Positive, Negative, and Neutral ranges are defined on the Survey Form specific information. If a survey form does not have any responses, it does not appear on the report.



Survey Overview

For period beginning Thursday, January 27, 2011 and ending Tuesday, September 27, 2011

Name	Count	Complete	Incomplete	Positive	Negative	Neutral
CallCopy Customer Survey	12	11 (91.7%)	1 (8.3%)	4 (33.3%)	2 (16.7%)	4 (33.3%)

Survey Summary

For each survey form in a time period, calculates these categories. If a survey form does not have any responses, it does not appear on the report.

- **Score** – Total score of the survey responses and the total maximum possible score of a survey. The maximum possible score on a survey can vary based on the questions that a respondent is asked to answer. For example, one respondent may be asked to answer five questions with a total of 50 points. Another respondent, based on his/her answers, will be directed through seven questions with a total of 70 points. This fact must be considered when designing surveys.
- **Average Percentage (%)** – (Sum of each response’s score)/((Sum of the possible score for each form)/Number of responses)



Survey Summary

For period beginning Thursday, January 27, 2011 and ending Tuesday, September 27, 2011

Name	Count	Complete	Incomplete	Positive	Negative	Neutral	Score	Avg %
CallCopy Customer Survey	12	11 (91.7%)	1 (8.3%)	4 (33.3%)	2 (16.7%)	4 (33.3%)	76 of 90	80.8%

Survey Summary by Agent

This report allows you to select a set of agents over a specific date range, and displays the number of surveys completed for each agent, given survey score, total possible points, percentage overall score, and totals for each column.

The Report Type option determines how results are broken down and displayed:

- Agent – Lists total scores for all forms by agent as shown below.
- Form – For each agent, shows scores by form and the total scores for all forms.
- Section – Shows scores for each section on the form.
- Question – Shows scores for each question in each section on each form.



Survey Summary by Agent

For Saturday, January 01, 2011 to Wednesday, August 08, 2012

Selected Agents: Orlando de Boer, Matt Borghetti, Jenny Bouclier, Joe Brechin, Anders Brooker, Keith Burke, James Busker, Stian Byrd, Jeremy Carrozza, Dimitri Carstensen, Renato Chassagne, Boozoo Chavis, Roy Chenier, Lemony Cicierega, Anthony Condon, Jean-Pierre Conlee, Sheryl Coscia, Gianni Croissonnier, Alan Crow, Richard Cunningham, Pietro Cutting, Rolf Deiro, Wolfgang DiGrolamo, Kevin Dimetrik, Gary Doktorski, Stuart Dwyer



Agent	# Surveys	Score	Possible	Percentage
Joe Brechin	2	4	5	80%
Stian Byrd	4	7	15	46%
Alan Crow	12	25	40	62%
Pietro Cutting	4	11	15	73%
Total:	22	47	75	63%

Survey Summary by Question

This report provides a count of each given response to each of the questions in a survey form. Users can select a date range, the survey form to evaluate, DNIS/ANI numbers, and whether the survey completion status. The generated report displays how many of the chosen survey have been completed, average score, then counts and score percentages of each question in the form. The Survey field is required.

Start Date: 1/1/2009 End Date: 8/8/2012 Survey: surveyFor5090
 DNIS: ANI: Survey Complete: Complete

of 1 of 1 Find | Next

Survey Summary by Question

For period beginning Thursday, January 01, 2009 and ending Wednesday, August 08, 2012

Selected Form: surveyFor5090

Survey	Number of Surveys	Average Score
surveyFor5090	0	0 of 0 (N/A)

Question	Response	Count	Percentage
Q1 On a scale of 1 to 5 - 5 is the best			
	1	0	0.0%
	2	0	0.0%
	3	0	0.0%
	4	0	0.0%
	5	0	0.0%
Q2 On a scale of 1 to 5 - 5 is the best			
	1	0	0.0%
	2	0	0.0%
	3	0	0.0%
	4	0	0.0%
	5	0	0.0%
Q3 On a scale of 1 to 5 - 5 is the best			
	1	0	0.0%
	2	0	0.0%
	3	0	0.0%
	4	0	0.0%
	5	0	0.0%
Thank you for your time			

Survey Summary by Question - 8/8/2012 CallCopy Recorder Reporting Service Page 1 of 1

Survey Summary by Response

This report allows users to identify the relationship between a response to one question and the responses to other questions. This allows you to see how different segments of the surveyed population have answered questions. For this report, one question can address a respondent's overall opinion of a product or service. Follow-up questions elicit the reasons or factors that cause that overall opinion.

Example: Car Satisfaction Survey – Customers who purchased any new car within the last year are surveyed. One question asked them to rate their overall satisfaction with their car on a scale of 1 to 5, with 5 being the highest satisfaction. Additional questions ask how many times they have taken the car for repairs, the price of the car, the size of the car, the car's miles-per-gallon rate, and whether the car was the customer's first choice. Assume that these are the results:

Report 1: Question 1: Satisfaction rating: 1

- Question 2 -- Number of times cars repaired: 1
- Question 3 – Was this car your first choice?: No

Report 1: Question 1: Satisfaction rating: 5

- Question 2 -- Number of times cars repaired: 1
- Question 3 – Was this car your first choice?: Yes

Given these results, it appears that satisfaction with a car purchase is determined by whether or not the customer was able to purchase their first choice. A customer may have wanted a \$35,000 car but had to settle for a \$20,000 car, which affected the satisfaction rating.

Multiple versions of this report may need to be created in order to identify the relationships between a question's responses and the responses on the other questions. In other words, Question 1 has four possible responses, and that question is used as the overall or control question, then a report should be run for each response.

Survey, Question ID, and Response are required fields. The result fields are

- Count – Number of respondents who selected a response.
- Score – Actual total points for a response. If a response was worth two points and three respondents selected it, the Score would be six.
- Possible Score – Multiplies the number of response options by the point value for a response.
- Percentage – $\text{Score} / \text{Possible Score}$

Reports

If no respondents selected a response to a question, the response option does not appear on the report. For example, if no respondents selected response 2 to a question, the report shows numbers for responses 1, 3, 4, and 5.

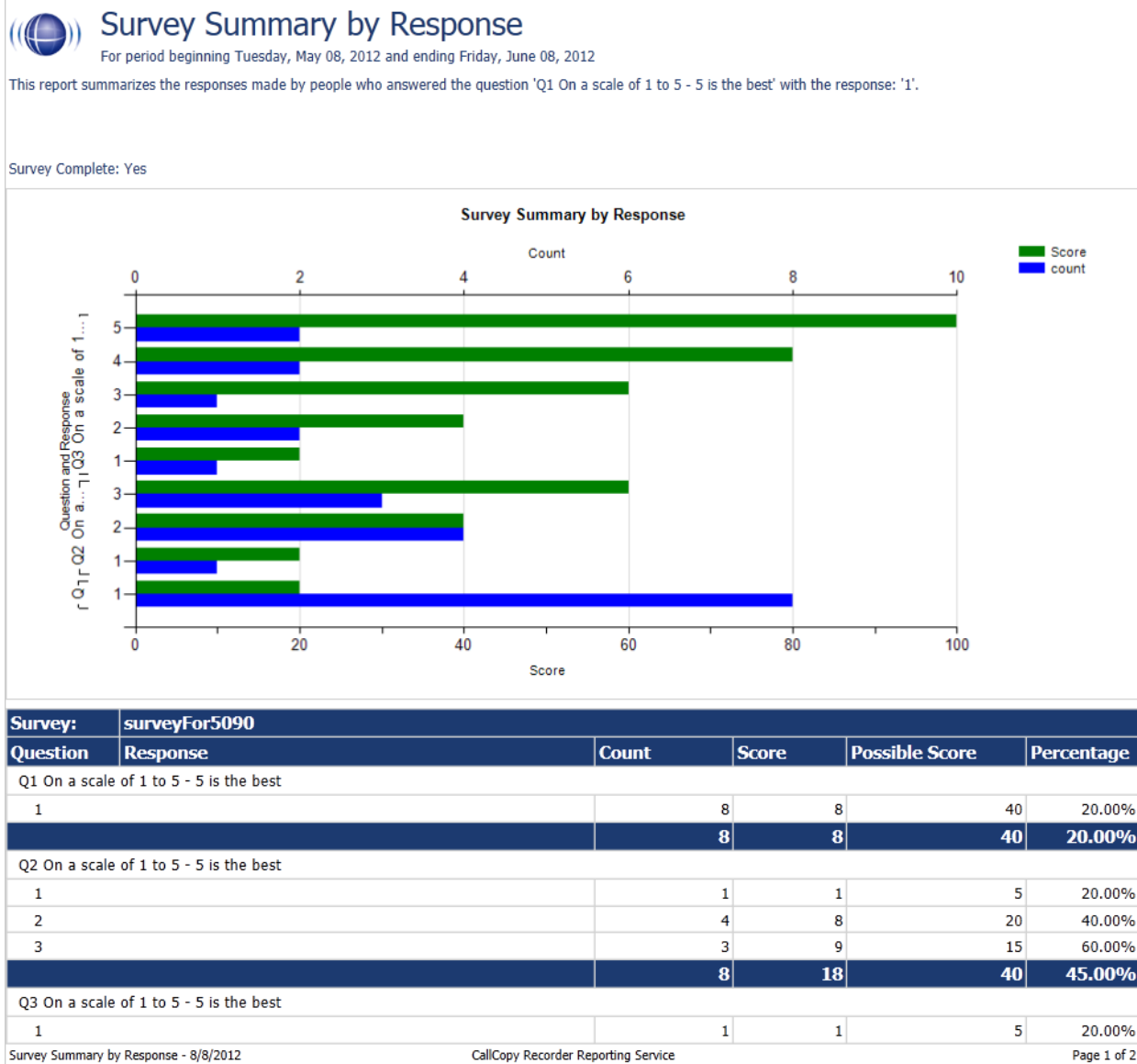

Example PBX Configurations

This section outlines **example** PBX configurations for T1s and trunk groups. This is not an inclusive list and CallCopy makes no guarantees that these configurations will work in your scenario. Please consult your PBX support or vendor for specific questions regarding your installation.

AVAYA

DS1 Circuit Pack

```

CC Avaya: display dsl 01v3 (page 1) 10/27/2008 5:29:20 PM

                                DS1 CIRCUIT PACK

      Location: 001V3                      Name: * Survey Trunk
      Bit Rate: 1.544                      Line Coding: b8zs
Line Compensation: 1                      Framing Mode: esf
      Signaling Mode: isdn-pri
      Connect: pbx                          Interface: network
      TN-C7 Long Timers? n                  Country Protocol: 1
Interworking Message: PROgress             Protocol Version: b
Interface Companding: mulaw                CRC? n
      Idle Code: 11111111                  DCP/Analog Bearer Capability: 3.1kHz

                                T303 Timer(sec): 4

      Slip Detection? y                      Near-end CSU Type: other

Echo Cancellation? y                      Block Progress Indicator? n
      EC Direction: inward
      EC Configuration: 4

```

```

CC Avaya: display dsl 01v3 (page 2) 10/27/2008 5:29:20 PM

                                DS1 CIRCUIT PACK

      ESF DATA LINK OPTIONS

                                Network Management Protocol: tabs
Send ANSI-T1.403 One-Second Performance Reports? n
                                Far-end CSU Address: b

```

Trunk Group Configuration

```

CC Avaya: display trunk-group 10 (page 1) 10/27/2008 5:28:47 PM

                                TRUNK GROUP

Group Number: 10                Group Type: isdn                CDR Reports: y
Group Name: * Nortel            COR: 1                TN: 1                TAC: *111
Direction: two-way            Outgoing Display? y        Carrier Medium: PRI/BRI
Dial Access? y                Busy Threshold: 255        Night Service:
Queue Length: 0
Service Type: tie                Auth Code? n                TestCall ITC: rest
TestCall BCC: 4                Far End Test Line No:
    
```

```

CC Avaya: display trunk-group 10 (page 3) 10/27/2008 5:28:47 PM

TRUNK FEATURES
  ACA Assignment? n                Measured: none                Wideband Support? n
                                      Internal Alert? n                Maintenance Tests? y
                                      Data Restriction? n            NCA-TSC Trunk Member:
                                      Send Name: y                    Send Calling Number: y
                                      Used for DCS? n                Send EMU Visitor CPN? n
  Suppress # Outpulsing? n        Format: public
  Outgoing Channel ID Encoding: preferred  UUI IE Treatment: service-provider

                                      Replace Restricted Numbers? n
                                      Replace Unavailable Numbers? n
                                      Send Connected Number: y
  Network Call Redirection: none        Hold/Unhold Notifications? n
  Send UUI IE? y                    Modify Tandem Calling Number? n
  Send UCID? y
  Send Codeset 6/7 LAI IE? y        Dsl Echo Cancellation? n
                                      US NI Delayed Calling Name Update? n
                                      Network (Japan) Needs Connect Before Disconnect? n
                                      Apply Local Ringback? n
    
```

```

CC Avaya: display trunk-group 10 (page 2) 10/27/2008 5:28:47 PM

Group Type: isdn

TRUNK PARAMETERS
  Codeset to Send Display: 6      Codeset to Send National IEs: 6
  Max Message Size to Send: 260  Charge Advice: none
  Supplementary Service Protocol: a Digit Handling (in/out): enbloc/enbloc

Trunk Hunt: cyclical

Digital Loss Group: 13
Incoming Calling Number - Delete:      Insert:      Format:
  Bit Rate: 1200      Synchronization: async      Duplex: full
Disconnect Supervision - In? y Out? n
Answer Supervision Timeout: 0
    
```

eOn eQueue

The following screenshots layout trunk configurations on an eOn eQueue.

T1 Line Assignment

```

Oct 29 08:12:24 ONLN      eOn eQueue      Rev:7.00.00-b01  equeue-a
Find      Add Change Delete      Print Quit
Line Assignment Modification
Number [E1750101]  Port [01.15.01 ]  Name [PRI TEST 1.15.1 ]
Line Info 1 [      ]  2 [      ]  3 [      ]
Type [TRUNK]  COS [1 ]  Group [1 ]  CallZone [ ]
Port Class [4 ]  T1 Class [5 ]  Password [      ]  VAN Grp [      ]
Lamp [0 ]  Aux Lamp [0 ]  Lamp Type [0 ]  Msg Lamp [0 ]
Port Comm. [      ]  IP [0 ]
Skill Set for Routing [      ]
Hotline/Direct In Number [D801 ]
Ring no Answer default [      ]
-----
FORWARDS
-----
Busy [      ]  Active [N ]  Internal ? [N ]
RNA [      ]  Active [N ]  Delay [      ]
All Calls [      ]  Active [N ]
Forward Setup Allowed  Internal [N ]  External [N ]
Find an assignment      F1 = HELP
    
```

T1 Class

```

Oct 29 07:14:23 ONLN      eOn eQueue      Rev:7.00.00-b01 equeue-a
Find Next Back Add Change Delete Print Quit
T1 Class Modification

T1 Index      [ 5]
Name          [ISDN W/D NETWORK ]

Protocol (ESF/D4/TR8) [ESF ]
Zero Suppression (AMI/B8Z) [B8ZS ]
Default CSU (P/S) [P ]
ISDN Signaling (Y/N) [Y ]
Clear D-Channel (Y/N) [Y ]
Maintenance Channel Format (O/1) [0 ]
Network or User (N/U) [N ]
Line Build Out [0 ]

Find an assignment F1 = HELP
    
```

Port Class

```

Oct 29 08:12:39 ONLN      eOn eQueue      Rev:7.00.00-b01 equeue-a
Find Next Back Add Change Delete Print Quit
Port Class Modification

Port Class No. [ 4] Name [ISDN B CHANNEL ] Type [ 14]
Pad Value 1000 Rx [ 0] Tx [ 0] 2000 [ 0]

Shelf Parameters :
1 [ 0] 2 [ 0] 3 [ 0] 4 [ 0] 5 [ 0] 6 [ 0]
7 [ 0] 8 [ 0] 9 [ 0] 10 [ 0] 11 [ 0] 12 [ 0]

Inbound Setup      Outbound Setup      Release Protocol
-----
Rx Ring            [N ] Tx Ring [N ]      Can't be Released [N ]
Tx Ack             [N ] Rx Ack [N ]      Re-Seize Guard Timer [ 0]
Tx Ans             [N ] Rx Ans [N ]
Decoder            [Y ] Tx Blck [N ]
No Answer on CONNECT [N ]

Electr. Set [N ]      Can Sup Inbound [Y ]      Wailed [N ]
Aux Line [N ]        Can Sup Outbound [Y ]
    
```

ISDN Group

```

Oct 29 07:14:59 ONLN      eOn eQueue      Rev:7.00.00-b01  equeue-a
Find Next Back Add Change Delete Print Quit
ISDN Group Modification
ISDN Group Number [ 2] Supergroup Number [0 ]
Primary D-Channel Interface ID [0 ]
Backup D-Channel Interface ID [ ]
Interface Type (P = PCM30/T = T1/V = VoIP) [T ]
ISDN Parameter Table [4 ]

Interface Identifier No. Starting Port No. of Ports
1 [ 0] [01.15.01 ] [23]
2 [ ] [ ] [ ]
3 [ ] [ ] [ ]
4 [ ] [ ] [ ]
5 [ ] [ ] [ ]
6 [ ] [ ] [ ]
7 [ ] [ ] [ ]
8 [ ] [ ] [ ]
9 [ ] [ ] [ ]
10 [ ] [ ] [ ]

Find an assignment F1 = HELP
    
```

ISDN Parameter

```

Oct 30 10:05:05 ONLN      eOn eQueue      Rev:7.00.00-b01  equeue-a
Find Next Back Add Change Delete Print Quit
ISDN Parameter Modification
Number [ 4] Name [NI SERV EXPL CH ]
Protocol Variant [NIS ]
Implicit Channel Identifier [N ]
Release vs Disconnect [N ]
Trunk Release (Transfer) [N ]
Protocol Test Mode [N ]
UUI Option [ ]
QSIG Name Delivery [N ]
QSIG Trunk Release (Forward) [N ]
QSIG Message Waiting [N ]
Default Values :
DNIS Type [ 0] DNIS Plan [ 0]
ANI Type [ 0] ANI Plan [ 1]
Facility [ 0] Bearer [ 0]

Find an assignment F1 = HELP
    
```

Hotline

```
Oct 30 10:07:04 ONLN      eOn eQueue      Rev:7.00.00-b01 equeue-a
Find Next Back Add Change Delete      Print Quit
Inbound Routing Modification
Number [ 17] Pilot [D801 ] Name [survey pri ] Copy From [ ]
Comment [ ] Zone [0 ]
Step      Command      Step      Command
[1 ] [ISDN ALERT      ] [2 ] [NULL      ]
[3 ] [NULL      ] [4 ] [NULL      ]
[5 ] [ROUTE DNIS, 80, 0 ] [6 ] [NULL      ]
[7 ] [NULL      ] [8 ] [NULL      ]
[9 ] [TERMINATE      ] [10] [      ]
[11] [      ] [12] [      ]
[13] [      ] [14] [      ]
[15] [      ] [16] [      ]
[17] [      ] [18] [      ]
[19] [      ] [20] [      ]
[21] [      ] [22] [      ]
[23] [      ] [24] [      ]
[25] [      ] [26] [      ]
[27] [      ] [28] [      ]
[29] [      ] [30] [      ]
[31] [      ] [32] [      ]
Enter inbound route entry name.      F1 = HELP CHANGE
```

Nortel

The following are sample configurations from a Nortel Option 11, LD screen 22:

```
CTYP MSDL
DNUM 8
PORT 1
DES CC_SVY
USR PRI
DCHL 19
OTBF 32
PARM RS422 DTE
DRAT 64KC
CLOK EXT
IFC NI2
    ISDN_MCNT 300
CLID OPT0
CO_TYPE STD
SIDE NET
CNEG 1
RLS ID 25
RCAP COLP NDS
T310 120
T200 3
T203 10
N200 3
N201 260
K 7
BSERV NO
```

About CallCopy

CallCopy, a leading provider of innovative call recording and contact center solutions, is dedicated to ensuring the highest standards of customer and employee satisfaction. The award-winning, enterprise-proven cc: Discover suite delivers advanced call recording, screen capture, quality management, speech analytics, performance management, customer survey and workforce management capabilities to organizations of all sizes and industries across the globe.

CallCopy empowers these organizations to gather business intelligence, which is leveraged to maximize operational performance, reduce liability, achieve regulatory compliance and increase customer satisfaction.

For more information, visit www.callcopy.com.